

For the Customers in the United States

OWNER'S RECORD

The model and serial numbers are located at the rear. Record these numbers in the spaces provided below. Refer to them whenever you call upon your Sony dealer regarding this product.

Model No. PS-LX520

Serial No. _____

WARNING

To prevent fire or shock hazard, do not expose the unit to rain or moisture.

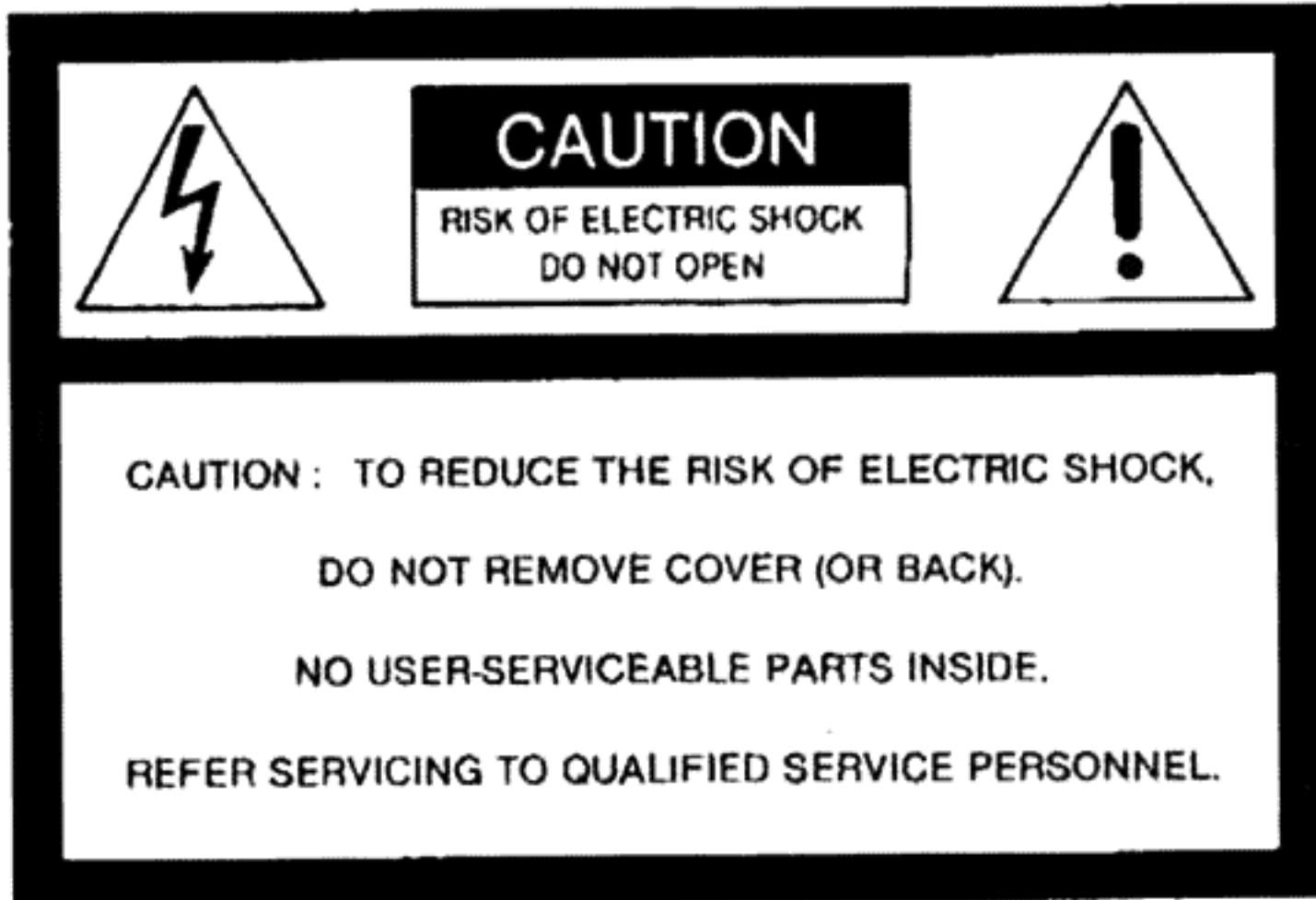

This symbol is intended to alert the user to the presence of uninsulated "dangerous voltage" within the product's enclosure that may be of sufficient magnitude to constitute a risk of electric shock to persons.



This symbol is intended to alert the user to the presence of important operating and maintenance (servicing) instructions in the literature accompanying the appliance.

*The graphical symbols are on the rear and bottom enclosure.

INFORMATION

This equipment generates and uses radio frequency energy and if not installed and used properly, that is, in strict accordance with the manufacturer's instructions, may cause interference to radio and television reception. It has been type tested and found to comply with the limits for a Class B computing device in accordance with the specifications in Subpart J of Part 15 of FCC Rules, which are designed to provide reasonable protection against such interference in a residential installation. However, there is no guarantee that interference will not occur in a particular installation. If this equipment does cause interference to radio or television reception, which can be determined by turning the equipment off and on, the user is encouraged to try to correct the interference by one or more of the following measures:

- reorient the receiving antenna
- relocate this equipment with respect to the receiver
- move this equipment away from the receiver
- plug this equipment into a different outlet so that equipment and receiver are on different branch circuits.

If necessary, the user should consult the dealer or an experienced radio/television technician for additional suggestions. The user may find the following booklet prepared by the Federal Communications Commission helpful:

"How to Identify and Resolve Radio-TV Interference Problems". This booklet is available from the U.S. Government Printing Office, Washington, DC 20402, Stock No. 004-000-00345-4.

As you read, fold back this page and refer to the illustrations on pages 3 and 4.

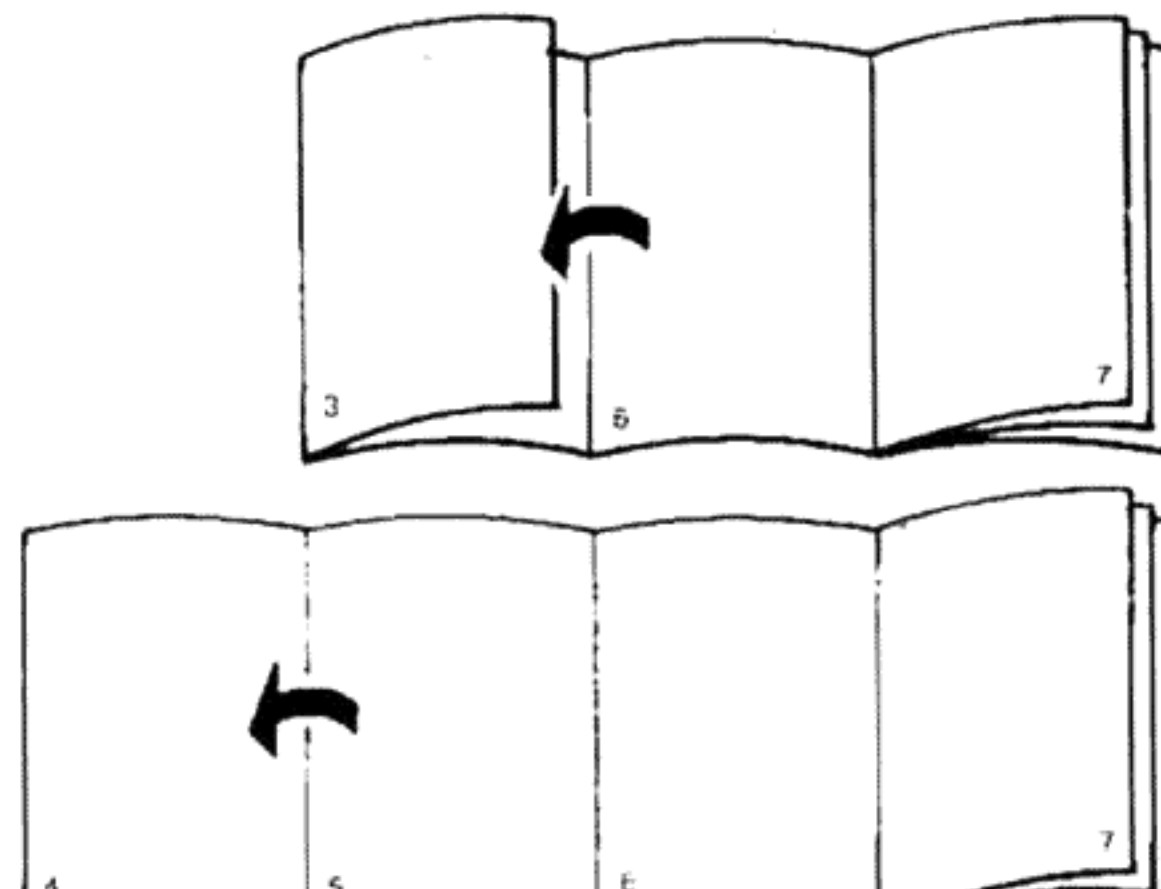

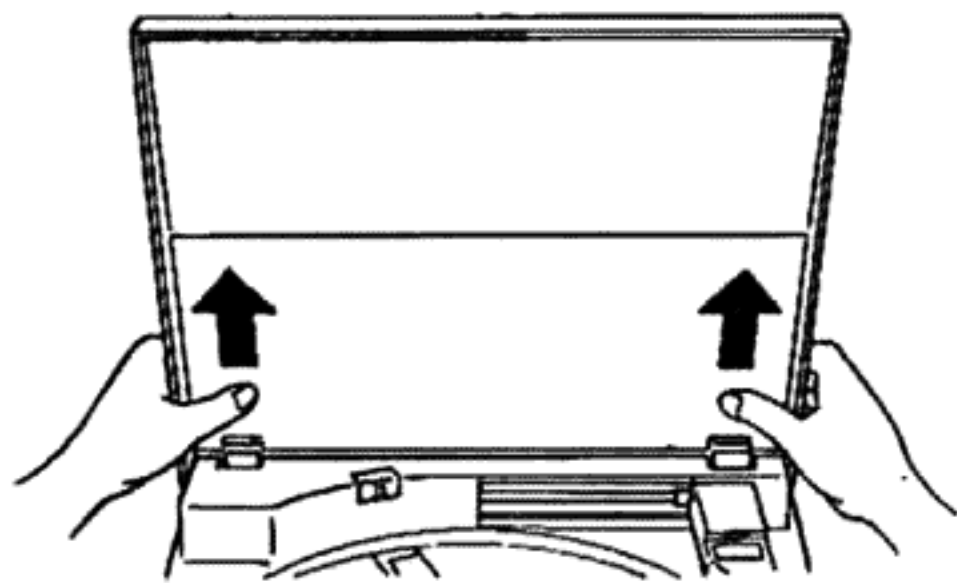
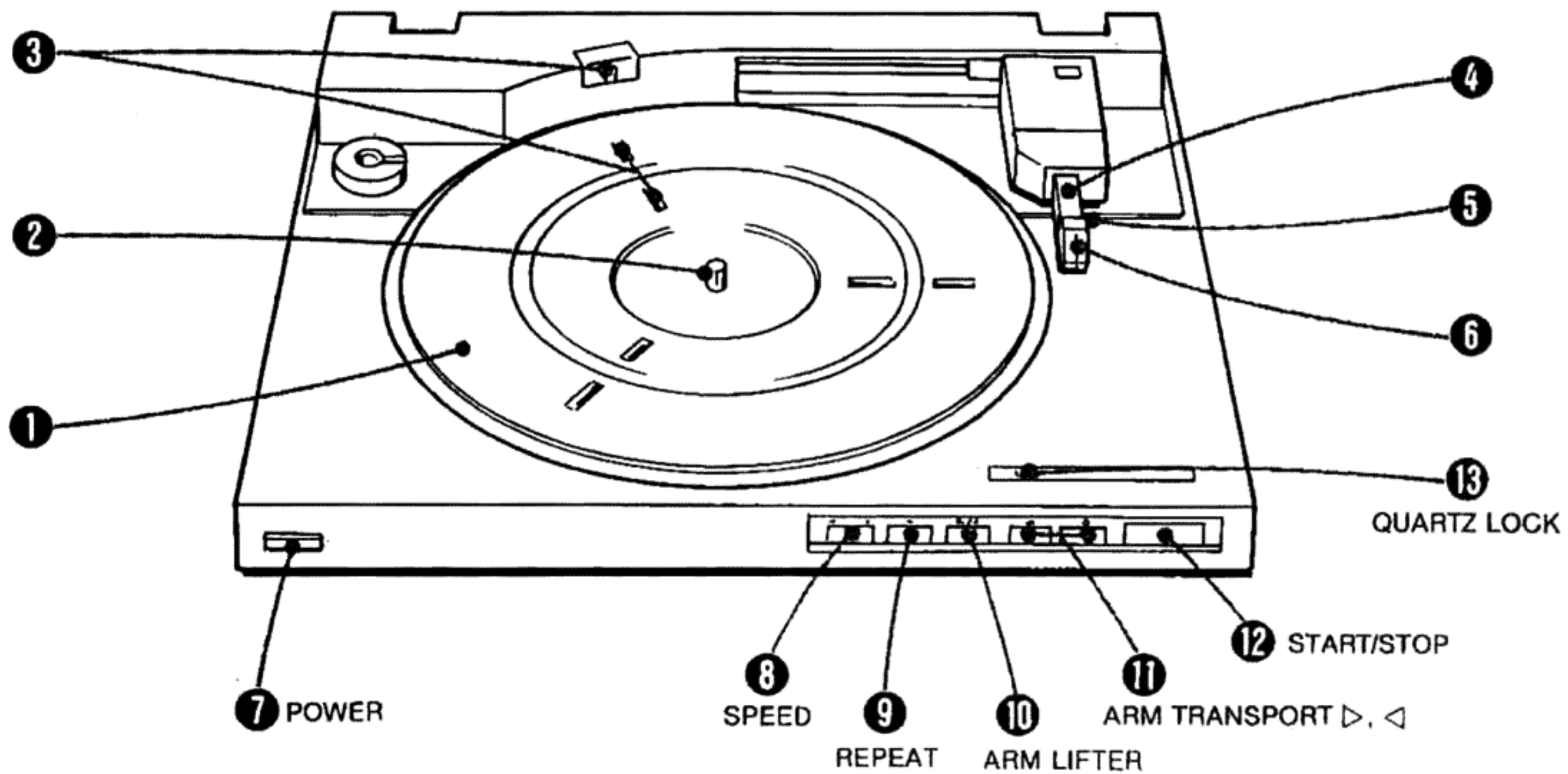
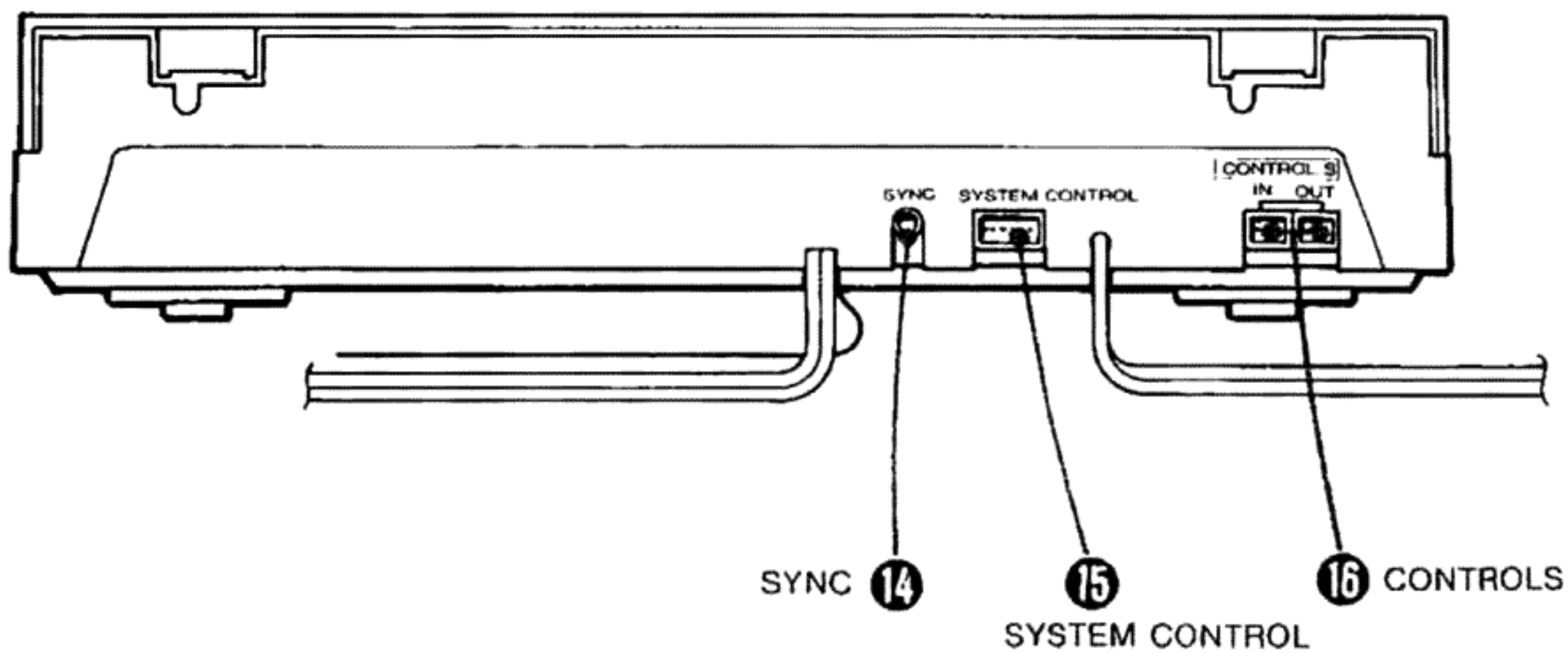
A**B****C**

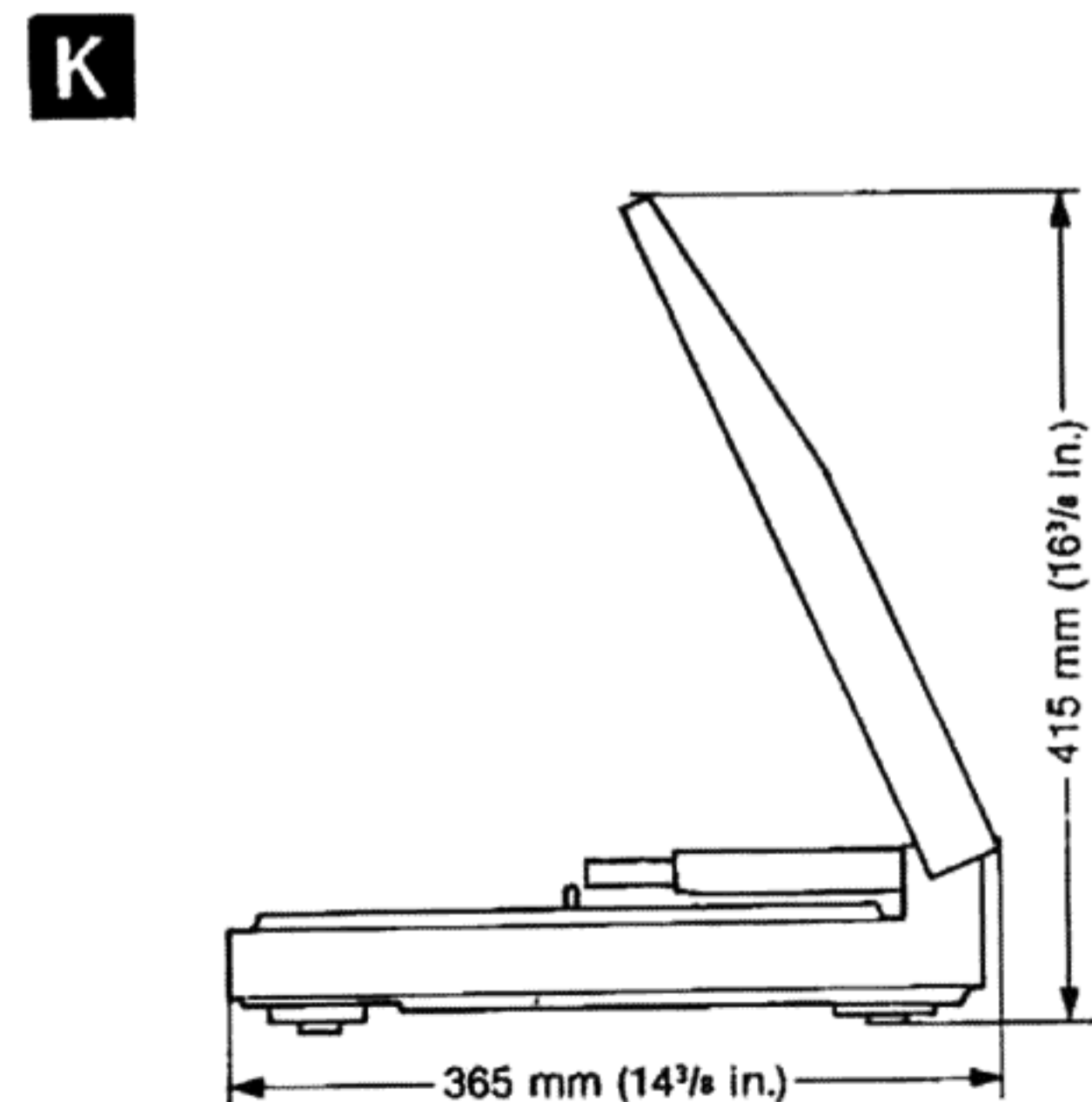
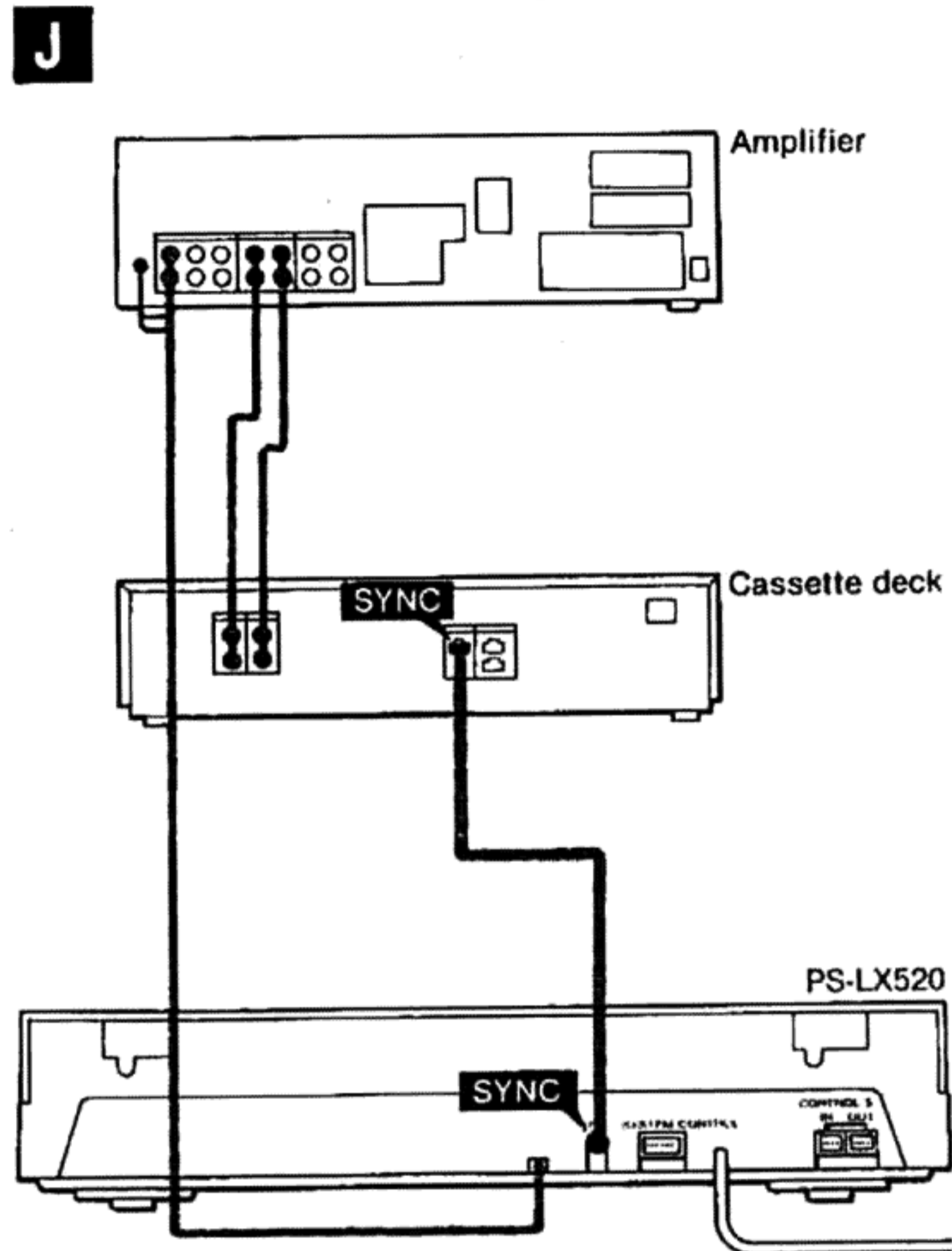
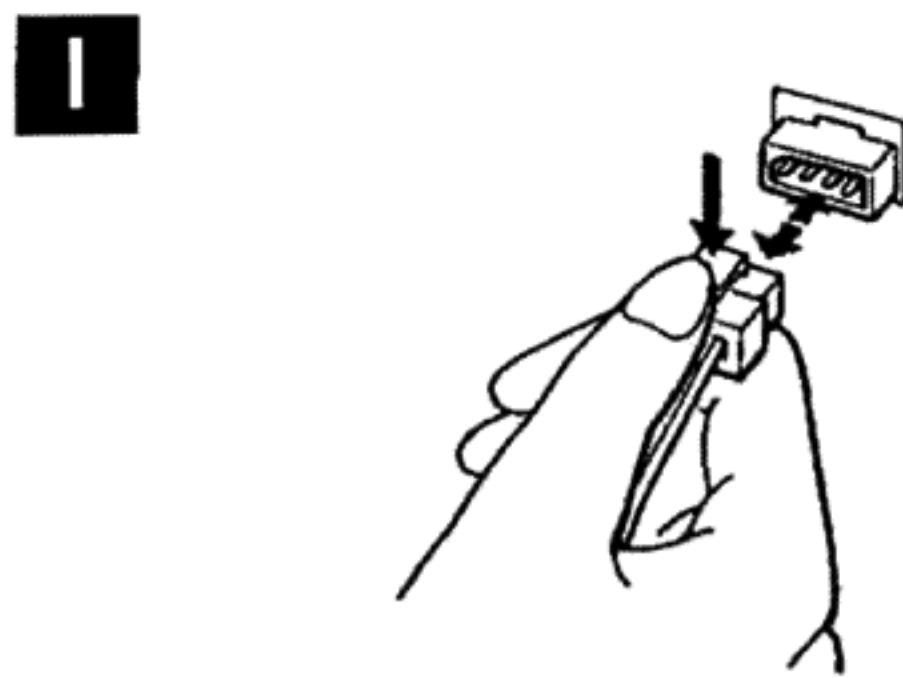
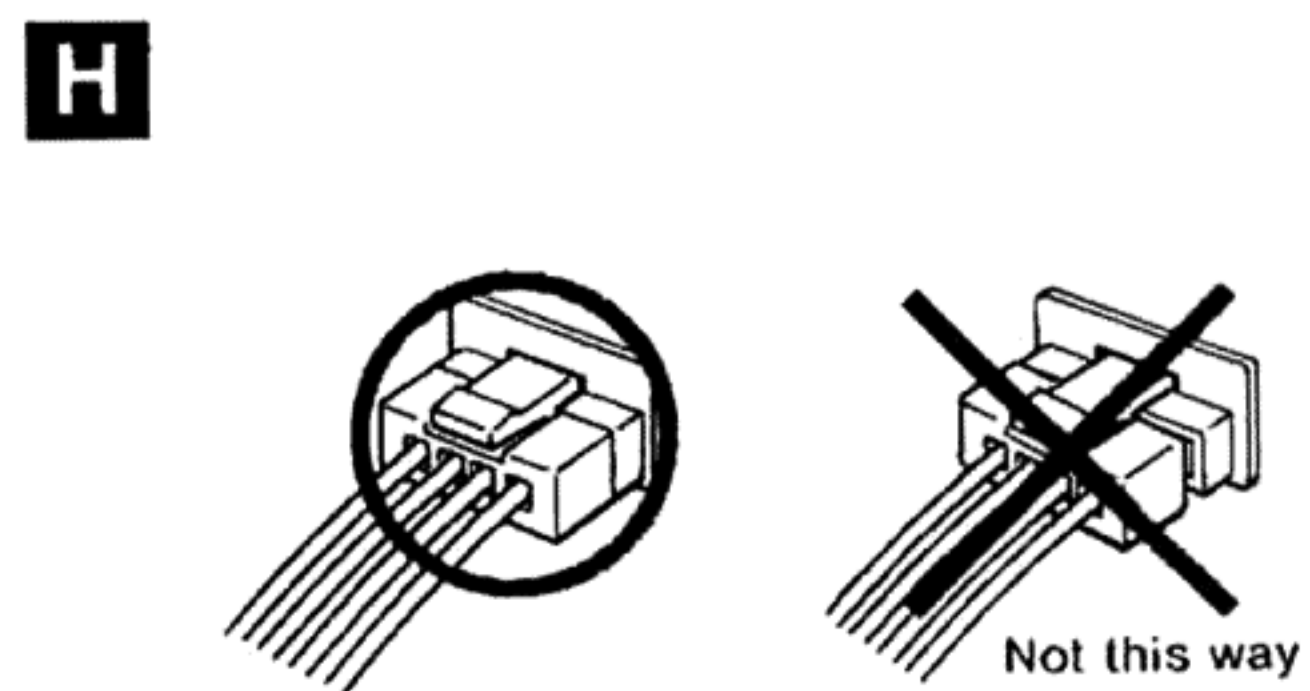
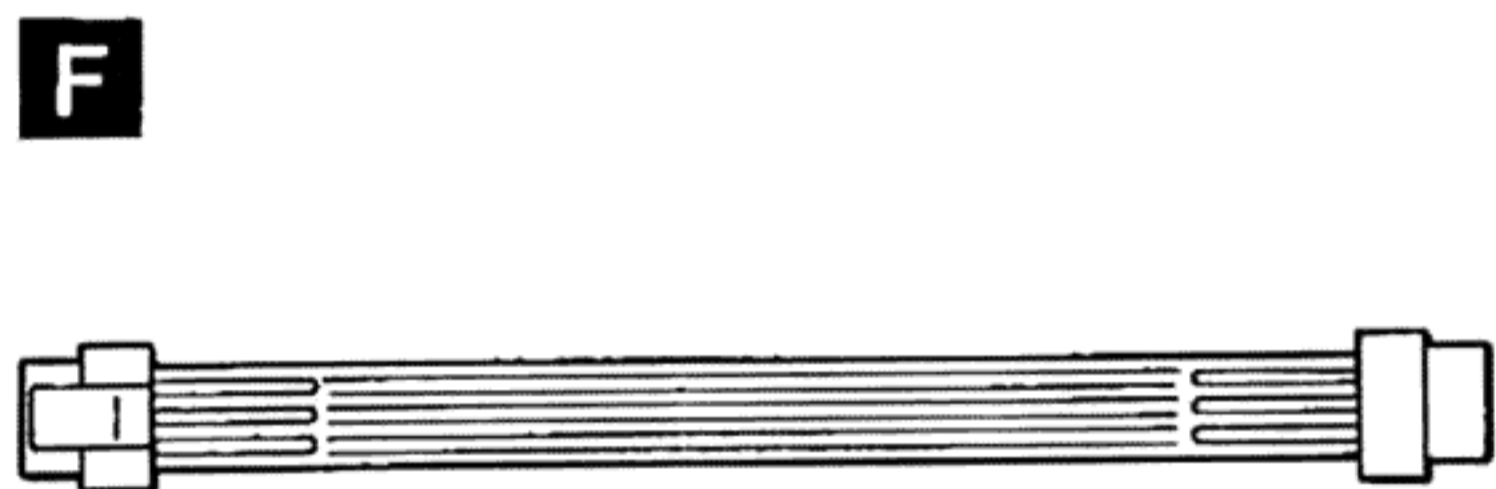
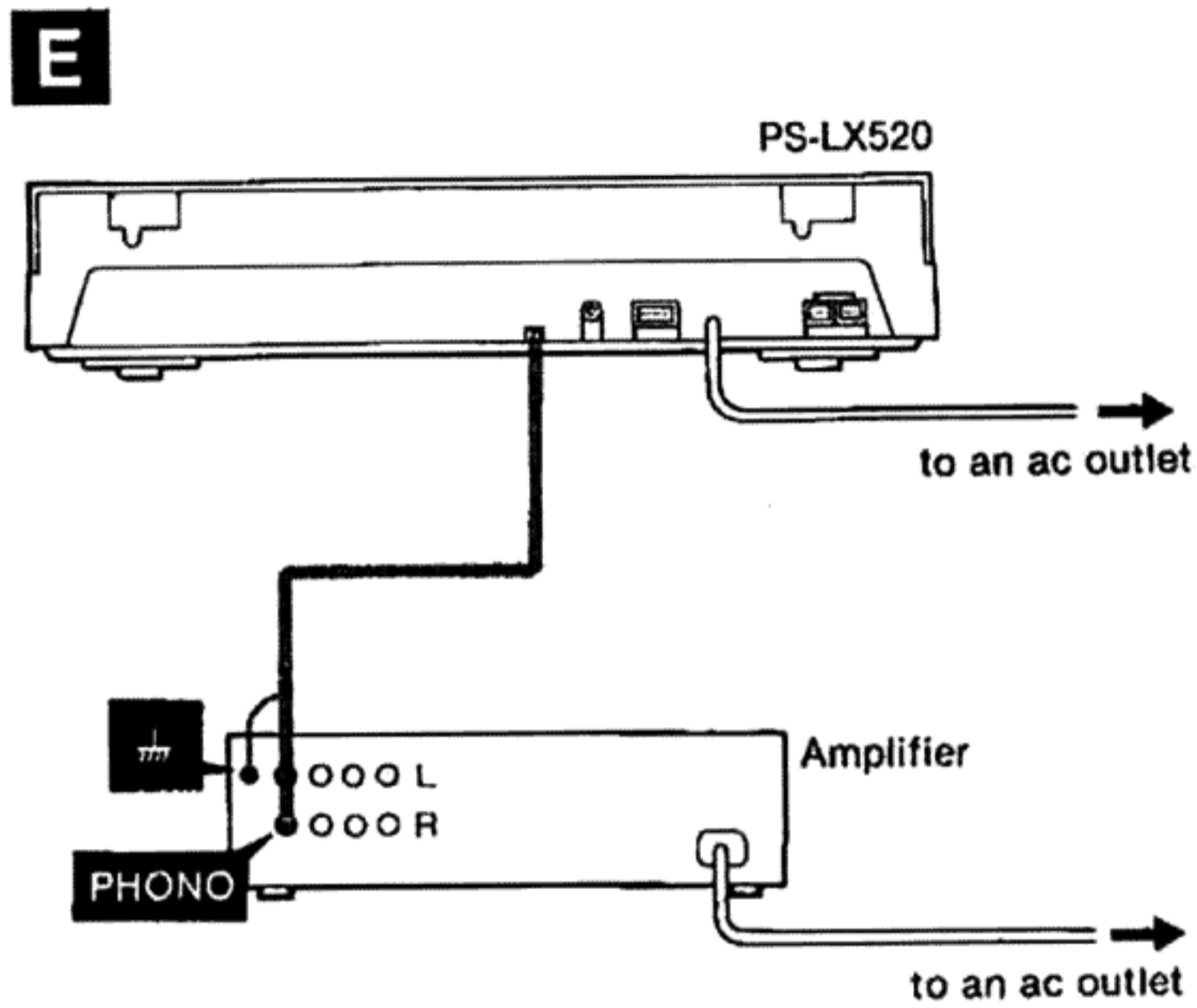
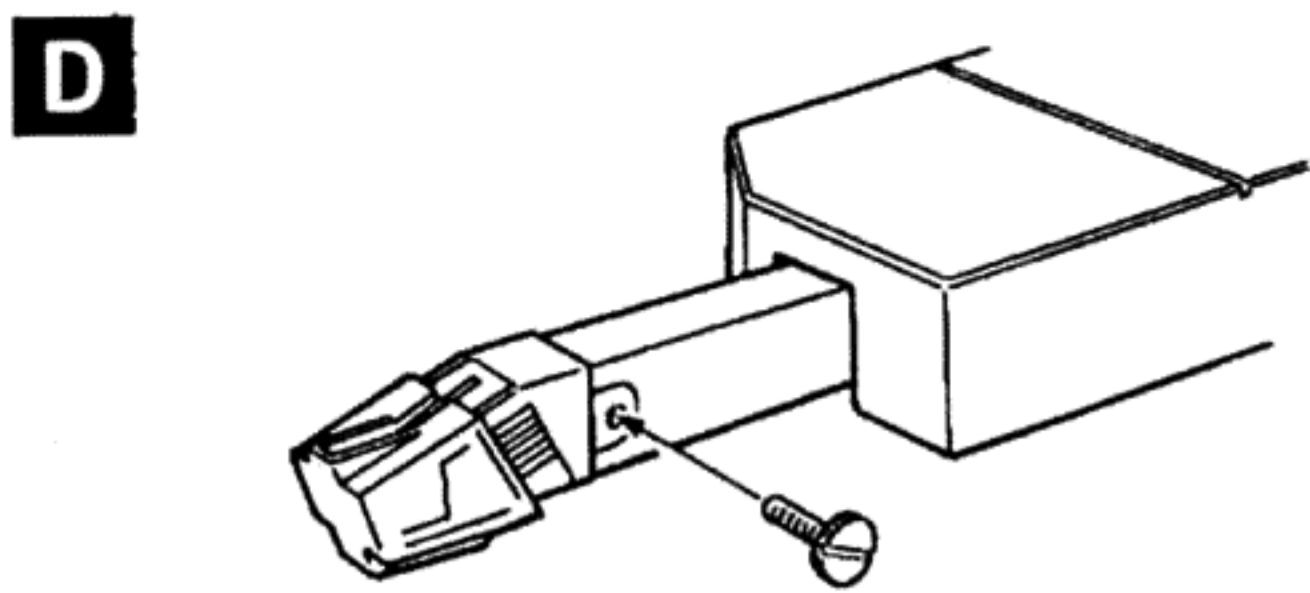

TABLE OF CONTENTS

Precautions.....	5
Location and function of controls	6
Cartridge installation.....	6
Turntable assembly	7
Connections.....	7
Signal connection.....	7
Remote control cord connection	7
Synchro remote control cord connection.....	7
Record playing.....	8
Preparation.....	8
Auto play	8
Manual play—To begin record play at a particular point	8
To move to a different part of a record during play	8
To lift up the stylus during play.....	8
To stop during play.....	8
To repeat play.....	8
Tips on record handling	8
Auto-record size selection system.....	9
Replacing the stylus.....	9
Synchronized play of the turntable and a cassette deck.....	10
Specifications	11
Trouble checks	11

For the customers in Canada

CAUTION:

TO PREVENT ELECTRIC SHOCK, DO NOT USE THIS POLARIZED AC PLUG WITH AN EXTENSION CORD, RECEPTACLE OR OTHER OUTLET UNLESS THE BLADES CAN BE FULLY INSERTED TO PREVENT BLADE EXPOSURE.

PRECAUTIONS

On safety

- Operate the unit only on 120 V ac, 60 Hz.
- Should any solid object or liquid fall into the cabinet, unplug the unit and have it checked by qualified personnel before operating it any further.
- Unplug the unit from the wall outlet if it is not to be used for an extended period of time. To disconnect the cord, pull it out by the plug. Never pull the cord itself.
- The unit is not disconnected from the ac power source (mains) as long as it is connected to the wall outlet, even if the unit itself has been turned off.

On installation

- Place the turntable on a level surface.
- Avoid placing the unit near electrical appliances (such as a television, hair dryer, or fluorescent lamp) which may cause hum or noise.
- Place the turntable where it will not be subject to any vibration, such as from speakers, slamming of doors, etc.
- Keep the unit away from direct sunlight, extremes of temperature, and excessive dust and moisture.

On dust cover removal

Open the dust cover fully and slide it upward with both hands.

(See illustration **A** on page 3.)

On repacking

Do not throw away the carton and packing materials. It is an ideal container in which to transport the unit. When shipping the unit to another location, repack it as illustrated on the carton box.

Before repacking, secure the tonearm using the arm clamp, spacers and transit screws as illustrated on page 7.

On cleaning

Before playing a record, clean the stylus with a soft brush. Brush the stylus from back to front. Never attempt to clean the stylus with your finger tip. If a fluid stylus cleaner is used, make sure not to moisten the stylus too much.

Clean the cabinet and dust cover periodically with a soft dry cloth. If the stains are difficult to remove, use a cloth moistened with a mild detergent solution. Do not use solvents such as alcohol, benzine or thinner, since they will damage the finish.

For the customers in the USA

For detailed precautions, see the leaflet "IMPORTANT SAFEGUARDS".

LOCATION AND FUNCTION OF CONTROLS

The illustrations **B** and **C** on page 3 show the assembled turntable.

Each number in the text is keyed to that of the illustrations.

Front panel

① Rubber mat

② Center spindle

③ Auto-record-size selection holes and lamp

See the chapter "AUTO-RECORD-SIZE SELECTION SYSTEM" on page 9.

④ Tonearm

⑤ Cartridge locking screw

⑥ Cartridge

⑦ POWER switch

⑧ SPEED selector and indicators

Selects the record speed. When the POWER switch is turned on, the speed is always 33 $\frac{1}{3}$ rpm and the indicator on the right illuminates. When the selector is pressed, 45 rpm is selected and the indicator on the left illuminates.

⑨ REPEAT button and indicator

Press this button to repeat play. The indicator illuminates and repeat play continues until this button is pressed to stop it.

⑩ ARM LIFTER button

This button lifts and lowers the tonearm. When the tonearm is on the arm rest position, this button cannot operate.

⑪ ARM TRANSPORT buttons

Press to move the tonearm inwards or outwards.

⑫ START/STOP button

Press this button to start the record playing. To stop during play, press it again.

⑬ QUARTZ LOCK indicator

The indicator illuminates when the turntable rotation is locked to the nominal speed by the quartz lock control system. The indicator goes out when the turntable rotation is out of the nominal speed.

Rear panel

⑭ SYNC connector

Connect a Sony cassette deck equipped with a flat 3-pin synchro remote control connector for synchronized play function.

⑮ SYSTEM CONTROL connector

Connect to the PHONO connector of the RM-44 system remote controller (optional) for remote control operation.

When the RM-44 is connected to this connector, do not connect audio equipment to the CONTROL S connectors. This will cause malfunction of the remote control system.

⑯ CONTROL S connectors (4-pin)

OUT: Connect to the CONTROL S IN or **R** REMOTE IN connector of other Sony audio equipments with the supplied flat 4-pin remote control cord for remote control of the total audio system.

IN: Connect to the CONTROL S OUT or **R** REMOTE OUT connector of an optional Sony system control tuner or receiver for remote control of the total audio system.

CARTRIDGE INSTALLATION

A cartridge with **TAP** label (optional) can be installed.

For the model supplied with a cartridge :

A cartridge has been installed correctly at the factory. So the installation procedures should be skipped unless you replace the cartridge.

The **TAP** label indicates that a cartridge is a standardized plug-in type.

- 1 First remove the cartridge locking screw.
- 2 Plug the cartridge into the tonearm and tighten the cartridge locking screw firmly. (Fig. **D**)

Note: The screw cannot be installed from the opposite side.

TURNTABLE ASSEMBLY

Do not connect the connecting cords until the turntable has been completely assembled.

Remove all packing material and wipe off the cabinet. Save the packing box and materials for possible future use.

- 1 Remove the two transit screws, the arm clamp and spacers. Save these screws, arm clamp and spacers, since they will be required when repacking.

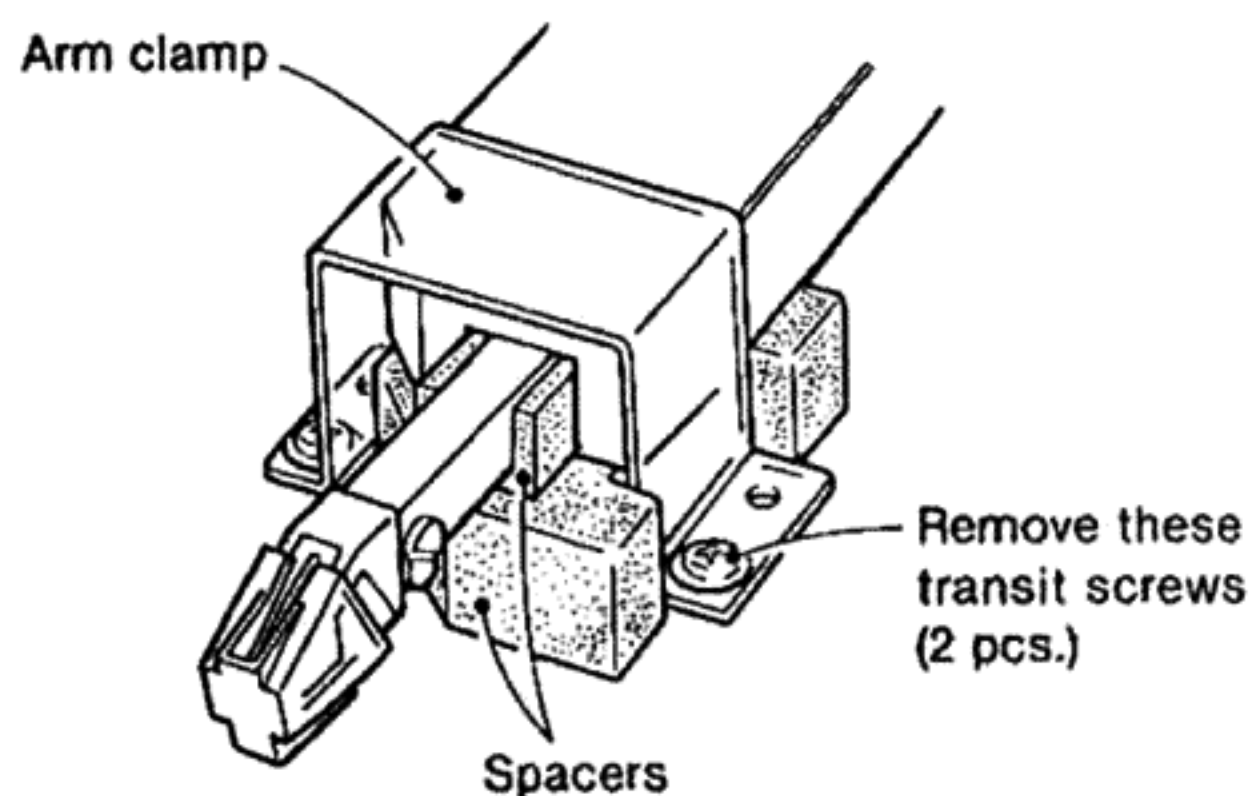

- 2 Connect the power cord to an ac outlet and press the POWER switch. The tonearm moves to the arm rest position.
- 3 Place the platter on the motor board.
- 4 Place the rubber mat on the platter so that the holes for auto record size selection on the rubber mat and on the platter are matched correctly.

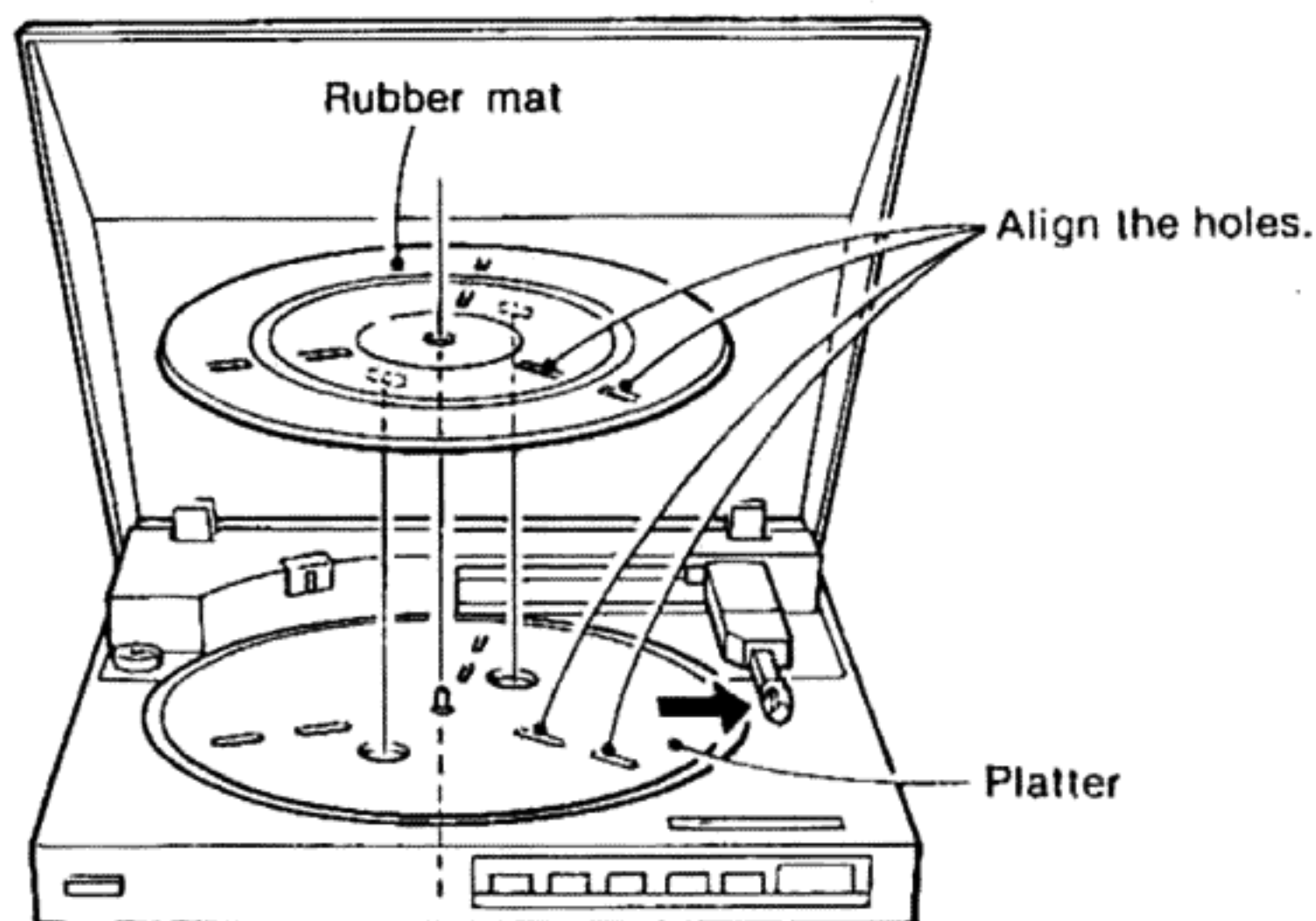

CONNECTIONS

SIGNAL CONNECTION

See Fig. **E** on page 4.

Notes

- Turn off the amplifier before making connections.
- Be sure to connect the red plug of the connecting cord to the right (R) jack and the remaining one to the left (L). The cable connectors should be fully inserted into the jacks. A loose connection may cause hum and noise.
- Leave a little slack in the connecting cord to allow for inadvertent shock or vibration.
- If the turntable causes interference to radio and television reception, turn off the turntable or move it away from the receiver.

REMOTE CONTROL CORD CONNECTION

Connect the supplied remote control cord (Fig. **F**) to the CONTROL S IN connector.

Notes

- Be sure to insert the cord securely. (Fig. **H**)
- To disconnect the cord, press the center tab and pull out the connector. Do not pull the cord itself. (Fig. **I**)

SYNCHRO REMOTE CONTROL CORD CONNECTION

Connect the supplied synchro remote control cord (Fig. **G**) to the SYNC connector. For details, refer to page 10.

RECORD PLAYING

PREPARATION

- Place a record on the platter. For 17 cm (7 inch) records, put the supplied 45-rpm adaptor over the center spindle.
- Set the input selector of the amplifier to PHONO.

AUTO PLAY

- 1 Press the POWER switch (⏻ ON).
- 2 Select the correct record speed.
- 3 Remove the stylus guard.



- 4 Press the START/STOP button.
- 5 Adjust the amplifier volume control.

When the tonearm reaches the end of the record, it will automatically return to the arm rest position.

Press the POWER switch to turn the unit off after the tonearm returns to the arm rest position.

Notes

● 25 cm (10 in.) records, transparent records and badly warped records cannot be played automatically. To play these records, proceed as in "AUTO-RECORD-SIZE SELECTION SYSTEM" on page 9.

● If the POWER switch is turned off while playing or while the tonearm is returning to the arm rest position, the tonearm will stop at that point, and will continue returning to the arm rest position when the POWER switch is turned on the next time. While the tonearm is returning, the START/STOP button does not activate the record playing.

MANUAL PLAY—To begin record play at a particular point

- 1 Press the ◀ button to move the tonearm to the desired position. If the tonearm is moved excessively, press the ▶ button to return it.
- 2 Press the ARM LIFTER button. The stylus lowers onto the record.
- 3 Press the START/STOP button. Play begins.

When the tonearm reaches the end of the record, it will automatically return to the arm rest position.

Press the POWER switch to turn the unit off after the tonearm returns to the arm rest position.

TO MOVE TO A DIFFERENT PART OF A RECORD DURING PLAY

Move the tonearm to the desired point of the record pressing the ARM TRANSPORT button and press the ARM LIFTER button to start play.

TO LIFT UP THE STYLUS DURING PLAY

To lift the stylus from a record for a moment, press the ARM LIFTER button. To lower the tonearm onto the record, press the button again. Playing will start from the same point.

TO STOP DURING PLAY

Press the START/STOP button. The turntable will stop rotating and the tonearm will return to the arm rest position.

TO REPEAT PLAY

Press the REPEAT button either before or after starting play. The indicator in this button illuminates. To cancel the repeat play, press the REPEAT button again. (The indicator goes off.)

Note

Transparent records and 25 cm (10 in.) records cannot be played repeatedly.

TIPS ON RECORD HANDLING

- Before playing, clean the record with a record cleaner or soft cloth. If a spray cleaner is used, make sure that it has dried completely before playing the record.
- Handle a record by its edges, and do not touch the grooves.
- Use a commercially available anti-static spray to neutralize the static electricity on a record.
- Avoid exposing a record to direct sunlight or sources of heat, such as a hot-air duct.
- Store your records vertically. They should not be compressed.

AUTO-RECORD-SIZE SELECTION SYSTEM

The auto-record-size selection system which only works during auto play, serves to detect using a beam from the lamp and the photo detectors whether there is a record or not on the platter and also to determine the record size.

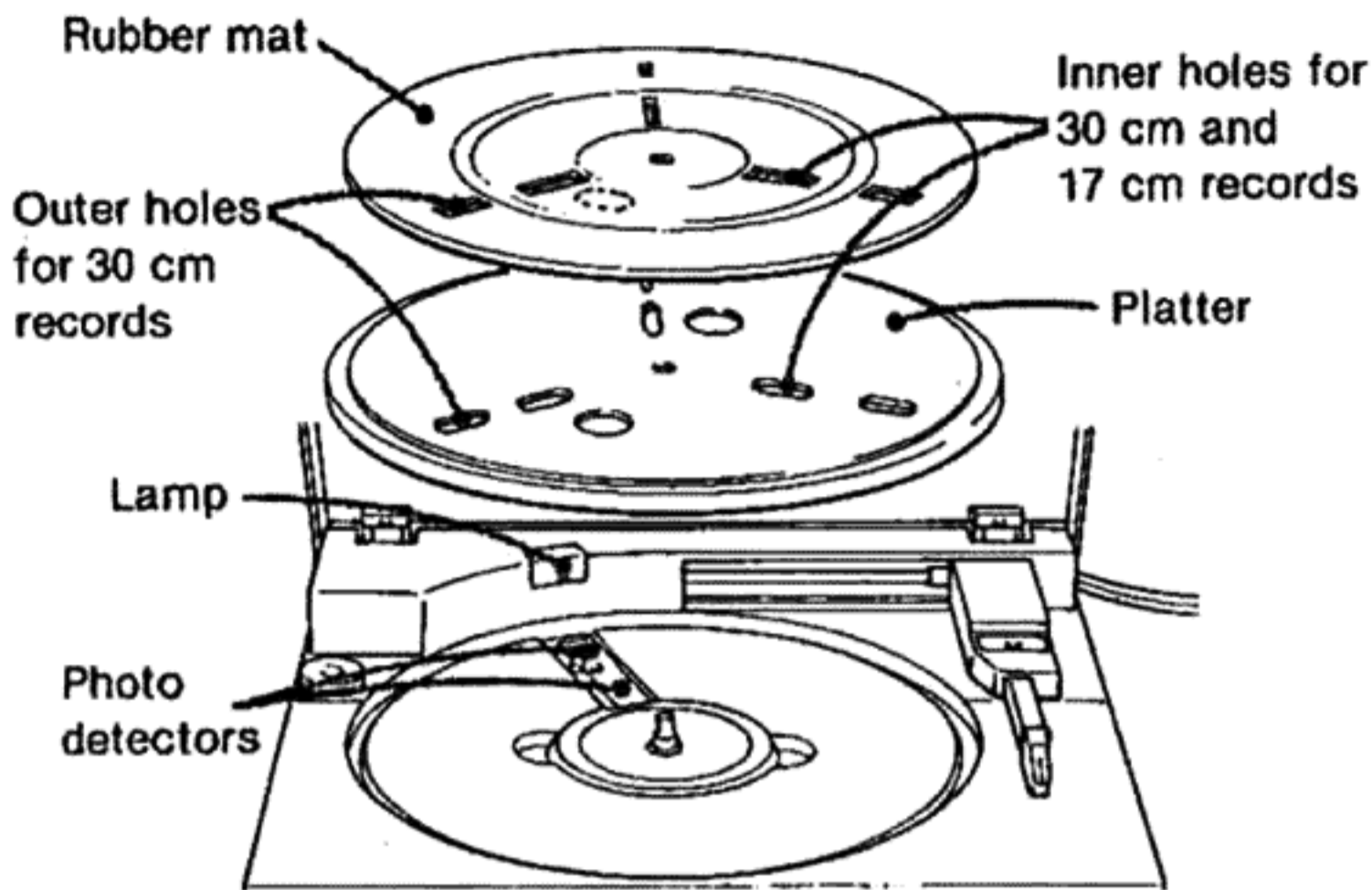

When a 30 cm record is to be played, both inner and outer holes are covered so no beam is transmitted to the photo detectors.

When a 17 cm record is to be played, the inner holes are covered so a beam is transmitted through the outer holes to the photo detector.

When there is no record on the platter, a beam is transmitted through both the inner and outer holes to the photo detectors. Even if the START/STOP button is accidentally pressed, the tonearm does not lower.

When a 25 cm record is to be played, the tonearm lowers to the same point that it would if a 17 cm record were on the platter, since both the inner holes are covered. To play a 25 cm record, proceed as in "MANUAL PLAY". At the end of the record, the tonearm will not automatically return to the arm rest position. Press the START/STOP button to return the tonearm to the arm rest position.

When a transparent record is to be played, a beam passes through both the inner and outer holes to the detectors so the tonearm does not lower onto the record. To play a transparent record, proceed as in "MANUAL PLAY".

In this case, auto-return will not activate at the end of the record. Press the START/STOP button to return the tonearm to the arm rest position.

The beam (infrared) sometimes passes through the normal record. Play these records as in "MANUAL PLAY".

When a badly warped record is to be played, a beam may pass through the holes to the detector(s) and cause a malfunction of the auto record size selection.

To play a warped record, proceed as in "MANUAL PLAY".

In this case, auto-return will not activate at the end of the record. Press the START/STOP button to return the tonearm to the arm rest position.

REPLACING THE STYLUS

Replace the stylus after about 400 hours of use because using a worn stylus will damage records. For the VL-45G cartridge (supplied with the specific models), an ND-145G replacement stylus is available at your Sony dealer.

The **TAP** label indicates that a cartridge is a standardized plug-in type.

- 1 First remove the cartridge locking screw and remove the cartridge.

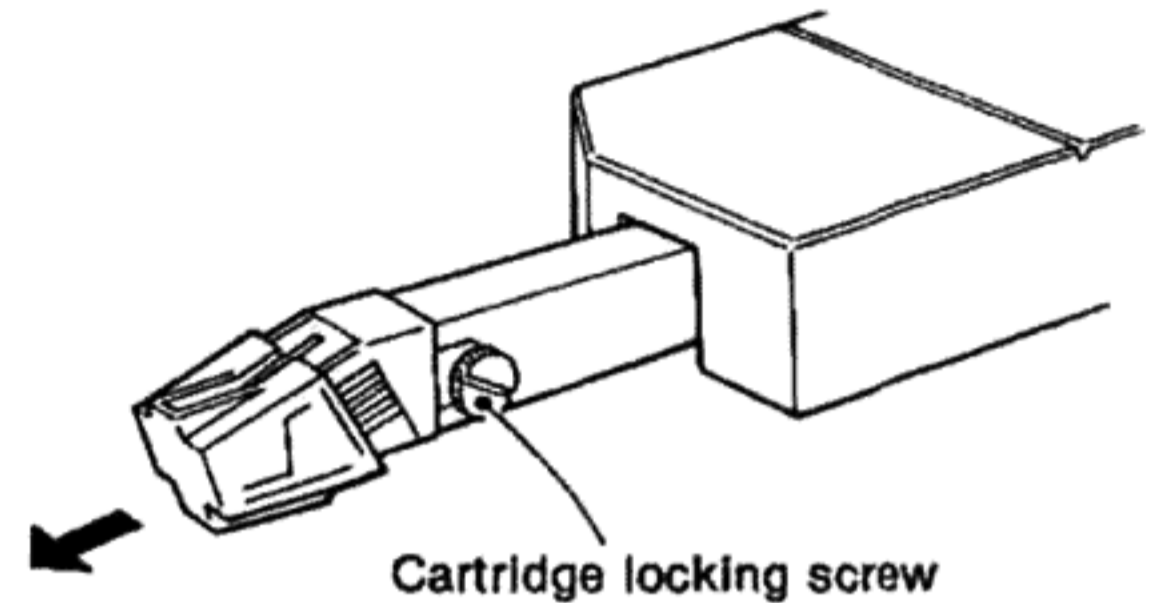

- 2 Detach the stylus assembly and insert a new stylus into the cartridge.

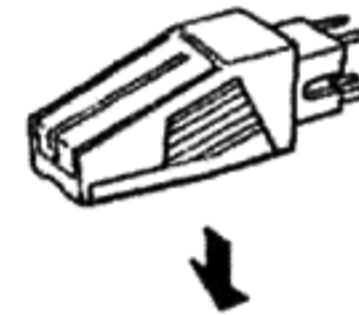

- 3 Plug the cartridge into the tonearm and tighten the cartridge locking screw firmly.

SYNCHRONIZED PLAY OF THE TURNTABLE AND A CASSETTE DECK

When the tonearm lowers onto the record, the cassette deck goes into the record mode and, when the tonearm is lifted up, the deck goes into the auto record muting mode for four seconds, then into the pause mode.

Cassette decks which can be used with your turntable for this special synchronized operation are those Sony models which are equipped with a 3-pin remote control connector.

For connection, see illustration  on page 4.

Synchro play can also be done with Sony cassette decks equipped with a 4-pin or 5-pin remote control jack but the RM-65 synchro remote control unit (optional) is required to connect the turntable and the cassette deck.

PREPARATION

- 1 Turn the amplifier on and set its input selector to PHONO.
- 2 Turn the turntable system on, place a record and select the correct record speed.
- 3 Adjust the recording level on the cassette deck and set it in the record stand-by mode.

RECORDING

Desired action	Turntable operation	Synchronized operation of the cassette deck
To record from the beginning of a record...	Press the START/STOP button.	When the tonearm lowers onto the record, the pause mode is released and recording begins.
To lift up the tonearm to move to a different point on a record...	Press the ARM TRANSPORT button.	When the tonearm is lifted up, auto record muting activates for four seconds, then the pause mode is assumed.
To record from a point some way in the record...	Move the tonearm to the desired point and press the START/STOP button.	When the tonearm lowers onto the record, the pause mode is released and recording begins.
To stop recording during record play...	Press the START/STOP button.	When the tonearm is lifted up, auto record muting activates for four seconds, then the pause mode is assumed.
When record play ends...	The tonearm returns automatically to the arm rest position.	When the tonearm is lifted up, auto record muting activates for four seconds, then the pause mode is assumed.

Notes

- When the PS-LX520 is not in use, be sure to set the POWER switch to OFF (□).
- To carry out synchronized recording, be sure to connect both the synchro remote control cord and audio cord. If not, synchro operation is not possible.
- When synchronized recording is not required, be sure to disconnect the synchro remote control cord, or if the RM-65 synchro remote control unit is used, be sure to set its SYNCHRO switch to OFF.

SPECIFICATIONS

Turntable

Platter	30 cm (12 in.), aluminum-alloy diecast
Motor	BSL (brushless and slotless) motor
Drive system	Direct drive
Control system	Quartz lock servo control system
Speed	33 $\frac{1}{3}$ rpm, 45 rpm
Wow and flutter	0.03% (WRMS)* ¹ 0.035% (WRMS)
Signal-to-noise ratio	75 dB (DIN-B)
Automatic system	Lead-in, return, reject, repeat, arm up/down, record size selection
Speed deviation	Within \pm 0.003%

Tonearm

Type	Linear tracking tonearm
Pivot-to-stylus length	75 mm (3 in.)
Tracking error	\pm 0.1°
Usable cartridge	Plug-in type, 6 g

Cartridge VL-45G (supplied only with the specific model)

Type	Moving magnet type
Frequency response	20 Hz to 20 kHz
Channel separation	20 dB at 1 kHz
Output voltage	3.5 mV at 1 kHz, 5 cm/sec., 45°
Load impedance	50 to 100 Kilohms
Tracking force	1.25 g
Stylus	Sony ND-145G
Weight	6 g

General

Power requirements	120 Vac, 60 Hz
Power consumption	10 W
Dimensions	Approx. 430 x 95 x 365 mm (w/h/d) (16 $\frac{7}{8}$ x 3 $\frac{3}{4}$ x 14 $\frac{3}{8}$ in.) including projecting parts and controls

(For the dimensions with the dust cover opened, see illustration **K** on page 4.)

Weight	Approx. 5 kg (11 lb), net Approx. 6.1 kg (13 lb 7 oz), in shipping carton
Supplied accessories	45-rpm adaptor (1) Remote control cord (1) Synchro remote control cord (1)

Design and specifications subject to change without notice.

*¹ This new measuring method concerns only the turntable assembly including the platter. It excludes wow and flutter caused by the tonearm, the cartridge, or the record. Measured by obtaining signal from magnetic pick-up head.

TROUBLE CHECKS

Should any problem persist after you have made these checks, consult your nearest Sony service facility. Before proceeding with these trouble checks, first refer to the connections and the operating procedures.

Impaired tone quality

- Dusty stylus.
- The turntable is not placed on a level surface.
- The turntable is incorrectly placed on or too near a speaker.
- Worn stylus or defective record. (The stylus life is approximately 400 hours of playing time.)
- Incorrect stylus installation.

No audio from one channel

- Loose connection of phono connecting cord.
- Low volume level setting for one channel of the amplifier.

Groove skipping, tonearm tends to skate, tonearm does not advance.

- The turntable is not placed on a level surface.
- Defective record.
- External vibrations.

Steady low-pitched hum

- Loose connection of phono cord.

Loud rumble or low-frequency howl*²

- The turntable is affected by external vibration.
- The turntable is too near a speaker.

*² This is called "acoustic feedback" and is caused when vibrations from the speakers are transmitted through the air or via solid objects (such as the shelves, the cabinet, the floor, etc.) to the turntable, where they are picked up by the stylus, amplified and reproduced through the speakers once again.